

INTERNAL TOP LOCKS Z-SERIES

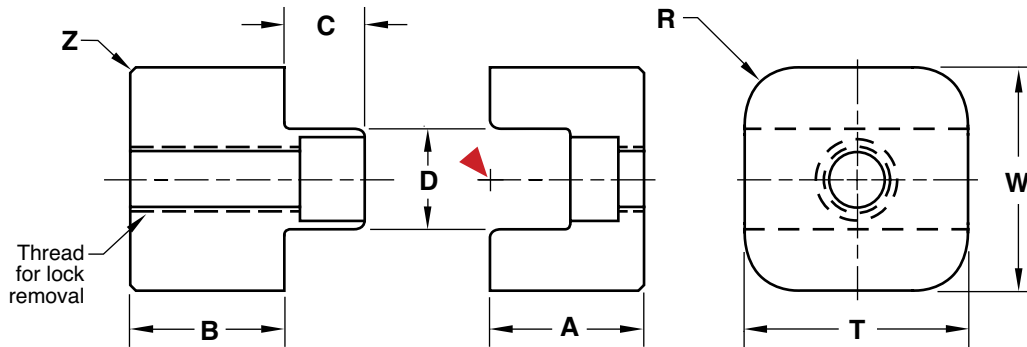

Inch Standard

Female: **M** D-2 **H** Core: 58-62 HRC, Surface: 80 HRC **S** Titanium Nitride Coated

Male: **M** H-13 **H** Core: 42-48 HRC, Surface: 70 HRC **S** Black Nitride

CAD insertion point

CATALOG NUMBER	T +.000 -.002	W +.0000 -.0004	A +.000 -.002	B +.000 -.002	C	D .0001/.0003 CLEARANCE PER SIDE	R POCKET RADIUS	Z	SHCS	
TL75X75	.750	.750	.625	.375	.275	.350	.188	.04	M: #6-32 x 3/4	F: #6-32 x 3/8
TL100X100	1.000	1.000	.875	.500	.450	.500	.250	.04	M: #10-32 x 1	F: #10-32 x 1/2
TL137X137	1.375	1.375	1.125	.625	.550	.750	.375	.04	M: 5/16-18 x 1-3/8	F: 5/16-18 x 3/4

Screws included.

Metric Standard

CATALOG NUMBER	T +.00 -.05	W +.00 -.01	A +.00 -.05	B +.00 -.05	C	D .002/.008 CLEARANCE PER SIDE	R POCKET RADIUS	Z	SHCS	
TLM20X20	20	20	14	14	7	9	5	1	M: M4 x 25	F: M4 x 10
TLM25X25	25	25	16	16	8	12	6	1	M: M5 x 25	F: M5 x 10
TLM32X32	32	32	20	20	10	16	7	1	M: M6 x 35	F: M6 x 12

Screws included.

APPLICATION GUIDELINES

- Internal Top Locks are designed to be installed into inserts or small/medium mold bases.

ALTERNATIVE CONFIGURATIONS AVAILABLE

- To order Shuttle Mold sets or special male/female configurations, refer to page C-11.
- Made-to-order Top Locks can be quoted using the templates at procomps.com.



SIDE/TOP/GUIDE LOCK SELECTION GUIDE

Refer to the chart below to match the correct alignment lock for the corresponding mold size and weight of the B-Side and press platen, using four locks per mold.

Clean and lubricate lock every 100,000 cycles, and prevent corrosion during mold storage.

RECOMMENDED MAX MOLD SIZE (LXWXH)	SIDE LOCKS	METRIC SIDE LOCKS	GUIDE LOCKS	TOP LOCKS	TOTAL MAX WEIGHT B SIDE + PRESS PLATEN (LBS/KG)
RTI AND MOLDS 8 X 8 X 8 AND SMALLER	SL37X100, SL50X125 SL50X150, SL50X200 SLS62X150, SLS62X200 SLR50X125, SLR50X150	SLM16X50, SLPM16X20 SLPM16X40, SLPM20X25 SLPM20X50, SLSM13X38 SLSM16X50	GL100X150 GLM25X45	TL75X75, TLM20X20 TL50X100, TL62X125 TL75X125, TLM26X35 TLR87X150	2,000 / 900
11 X 16 X 10	SL50X125, SL50X150 SL50X200, SLS62X150 SLS62X200, SLS75X300 SLS75X400, SLR50X150 SLR50X200	SLM16X50, SLSM19X75 SLPM25X32, SLPM25X63 SLPM32X40, SLPM32X80 SLPM40X50, SLPM40X100 SLSM19X100	GL100X150 GL150X250 GLM25X45	TL62X125, TL75X125 TL100X100, TLM25X25 TLM26X35 TLR87X150, TLR112X200	5,000 / 2,300
16 X 24 X 16	SL50X150, SL50X200 SL75X300, SLS112X500 SLS75X300, SLS75X400 SLR75X300, SLR100X400	SLM19X75, SLM19X100 SLSM25X125 SLPM50X56, SLPM50X112 SLRM32X63 SLRM40X100	GL150X250 GLM40X65	TL75X125, TL87X150 TL137X137, TLM32X32 TLM26X35, TLM30X45 TLR112X200 TLR150X250	7,000 / 3,200
28 X 34 X 24	SL75X300, SLS112X500	SLM19X75, SLM19X100	GL200X350 GL150X250 GLM40X65	TL100X150, TL100X200 TL112X200, TL112X300 TLM26X35, TLM30X45	10,000 / 4,500
32 X 40 X 28	SL100X400	SLM25X125	GL200X350 GLM40X65	TL112X200, TL112X300 TLM36X55, TLM36X75	15,000 / 6,800
42 X 48 X 34	SL125X500		GL250X450 GLM50X90	TL150X250, TL175X300 TLM36X55, TLM36X75	20,000 / 9,000
48 X 52 X 38	SL150X600		GL250X450	TL175X300, TL200X350 TLM45X100	26,000 / 11,800

BAR LOCK SELECTION GUIDE

MALE BAR CATALOG NUMBER	GUIDE CATALOG NUMBER	BAR LOCK ENGAGEMENT	TOTAL MAX WEIGHT SUPPORTED (LBS/KG)
BLB100L4	BLG100L1.3, BLG100L1.8 BLG100L2.3, BLG100L2.8	2.50	10,000 / 4,500
BLBX137L5	BLGT137L1.3, BLGT137L1.8	3.00	
BLB100L6	BLG100L1.3, BLG100L1.8 BLG100L2.3, BLG100L2.8	4.50	
BLBT137L6	BLGT137L1.3, BLGT137L1.8		
BLBM25L125	BLGM25L27, BLGM25L36	89mm	
BLB125L5	BLG125L1.3, BLG125L1.8 BLG125L2.3, BLG125L2.8	3.00	15,000 / 6,800
BLBX162L6	BLGT162L1.3, BLGT162L2.3	3.50	
BLB125L9	BLG125L1.3, BLG125L1.8 BLG125L2.3, BLG125L2.8	7.00	
BLBT162L9	BLGT162L1.3, BLGT162L2.3		
BLBM32L160	BLGM32L36, BLGM32L46	114mm	
BLB137L6	BLG137L1.8, BLG137L2.3 BLG137L2.8, BLG137L3.3, BLG137L3.8	3.50	20,000 / 9,000
BLBX200L7	BLGT200L1.8 & BLGT200L2.8	4.50	
BLB137L11	BLG137L1.8, BLG137L2.3 BLG137L2.8, BLG137L3.3, BLG137L3.8	8.50	
BLBT200L11	BLGT200L1.8 & BLGT200L2.8		
BLBM38L250	BLGM38L46, BLGM38L76	194 mm	
BLB150L8	BLG150L1.8, BLG150L2.3	4.50	26,000 / 11,800
BLB150L16	BLG150L2.8, BLG150L3.3, BLG150L3.8	12.50	
BLN150L8	BLG150L1.8, BLG150L2.3 BLG150L2.8, BLG150L3.3, BLG150L3.8	3.75	
BLN250L10	BLG250L4.3	5.00	
BLN350L13	BLG350L4.8	6.00	