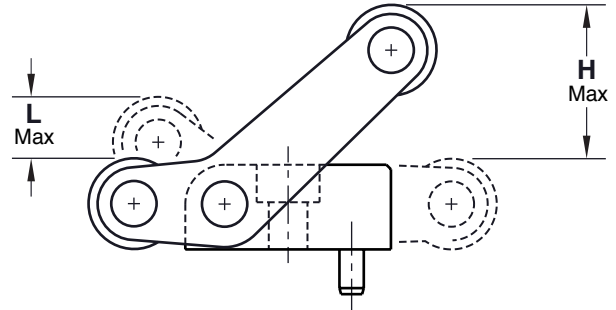
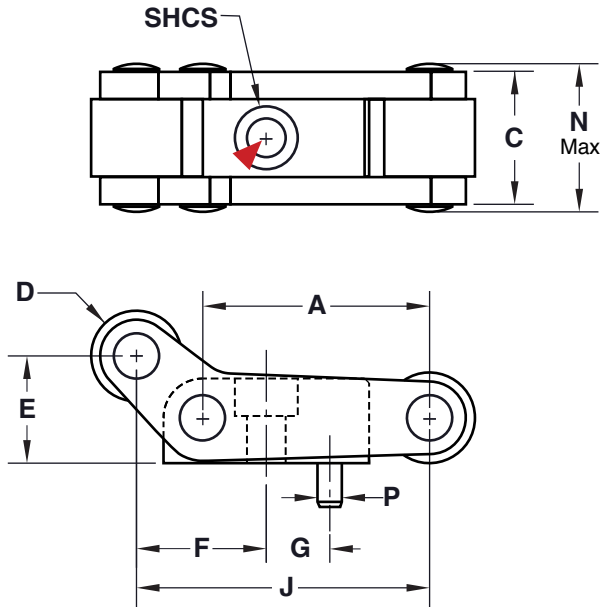



PLATE ACCELERATORS



APPLICATION GUIDELINES

- Use two or four Plate Accelerators per mold.

Arms: **M** H-13 **H** 46-50 HRC **S** Black Oxide
 Roller: **M** 52100 **H** 56-60 HRC

▶ CAD insertion point

CATALOG NUMBER	A	L	H	D	E	F	G	J	C	N	P	SHCS	MAX FORCE (KG/LBS)
ACCPM20	20	4.4	11.6	8	9.4	11.4	6	25.8	13.2	15	Ø2.5x5	M3x12	125 / 275
ACCPM25	25	5.7	15	10	11.8	14.3	7	32.3	16	18.5	Ø3x6	M4x16	250 / 550
ACCPM37	37.5	9.1	22	15	17.7	21.5	10.5	48.5	22	25	Ø4x8	M6x25	350 / 770
ACCPM50	50	12.5	34	20	23.6	28.6	14	64.6	30	34	Ø5x10	M8x30	800 / 1,760

Screw and dowel included.

